



PATOKA VALLEY

MATEUR RADIO CLUB



A Virtual Tour of *KC9YIM's* Station

John Doe's Biography



- Enjoys amateur radio
- Acquired technician license in 2013
- Upgraded to General in 2016

Amateur Radio is a great hobby. I'm a member of the Patoka Valley Amateur Radio Club.

Most Memorable Moment

W8F SPECIAL EVENT STATION

Commemorating the Forty-First
Anniversary of the Loss of the SS Edmund Fitzgerald

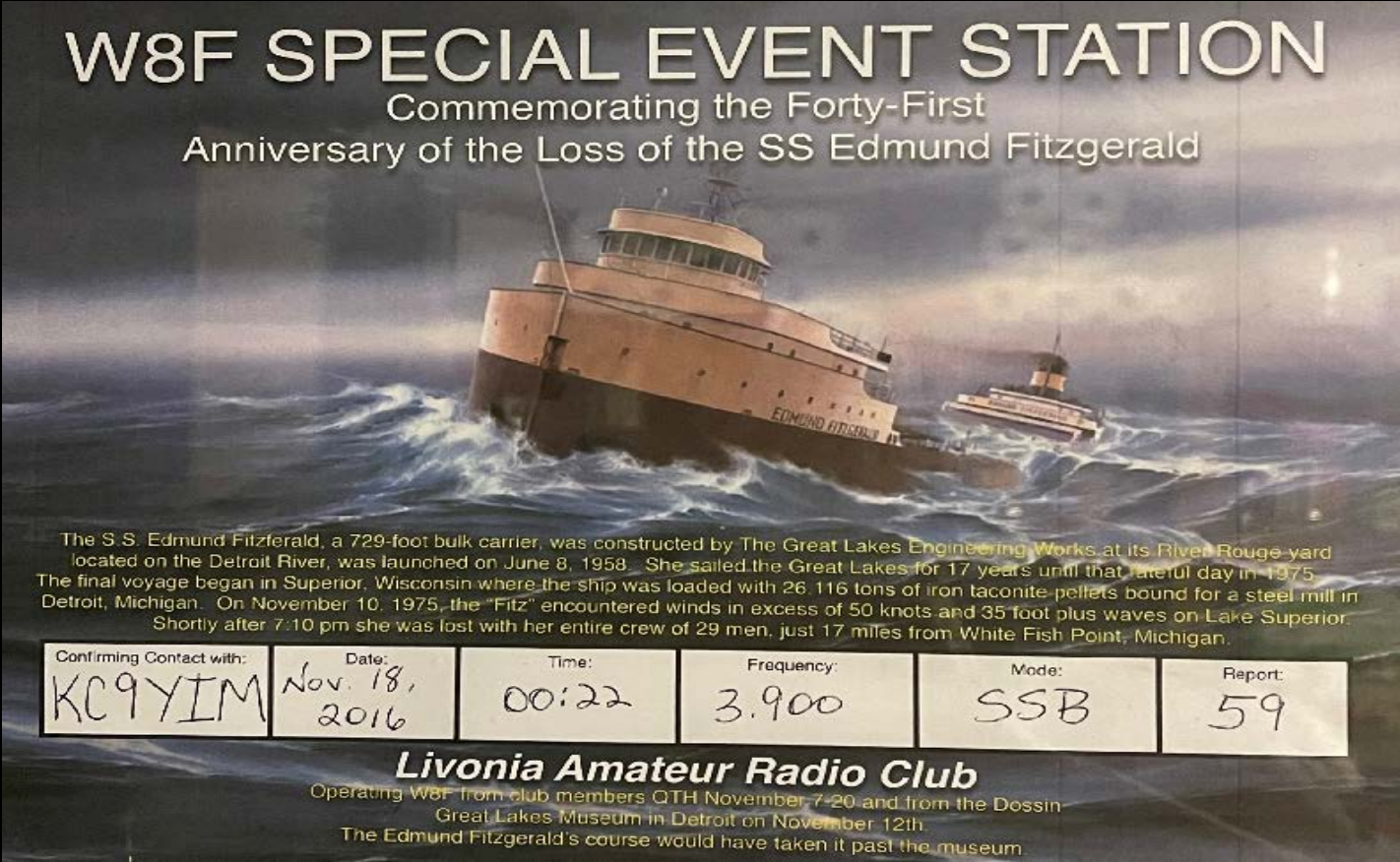

The S.S. Edmund Fitzgerald, a 729-foot bulk carrier, was constructed by The Great Lakes Engineering Works at its River Rouge yard located on the Detroit River, was launched on June 8, 1958. She sailed the Great Lakes for 17 years until that fateful day in 1975. The final voyage began in Superior, Wisconsin where the ship was loaded with 26,116 tons of iron taconite pellets bound for a steel mill in Detroit, Michigan. On November 10, 1975, the "Fitz" encountered winds in excess of 50 knots and 35-foot plus waves on Lake Superior. Shortly after 7:10 pm she was lost with her entire crew of 29 men, just 17 miles from White Fish Point, Michigan.

Confirming Contact with: KC9YIM	Date: Nov. 18, 2016	Time: 00:22	Frequency: 3.900	Mode: SSB	Report: 59
------------------------------------	---------------------------	----------------	---------------------	--------------	---------------

Livonia Amateur Radio Club

Operating W8F from club members QTH November 7-20 and from the Dossin
Great Lakes Museum in Detroit on November 12th.
The Edmund Fitzgerald's course would have taken it past the museum.

**Most remembered moment: the first HF contact,
special event station for the anniversary of the
sinking of the SS Edmund Fitzgerald**

KC9YIM's Station



KC9YIM's Equipment

- Yaesu 857d
- Yaesu Ftm100dr
- LDG YT100 Antenna Tuner
- Signal Link USB
- President Johnny III for CB
- Commercial power is supplied by a Jet stream switching power supply
- DC is supplied by 3, 10 Ah Dakota Lithium Battery's in parallel.
- Also Capable to hook Solar as well as an External battery bank.

KC9YIM's Antennas



- **Diamond v2000 tri band 6,2,70cm**
- **End fed wire antenna HF**
- **Astron 99 CB**

The DBJ-2: A Portable VHF- UHF Roll-up J-Pole Antenna for Public Service

March 2007 QST

The DBJ-2: A Portable VHF-UHF Roll-Up J-pole Antenna for Public Service

WB6IQN reviews the theory of the dual band 2 meter / 70 cm J-pole antenna and then makes detailed measurements of a practical, easy to replicate, "roll-up" portable antenna.

Edison Fong, WB6IQN

March 2007 QST

It has now been more than three years since my article on the dual band J-pole (DBJ-1) appeared in the February 2003 issue of *QST*.¹ I have had over 500 inquiries regarding that antenna. Users have reported good results, and a few individuals even built the antenna and confirmed the reported measurements. Several major cities are using this antenna for their schools, churches and emergency operations center. When asked why they choose the DBJ-1, the most common answer was value. When budgets are tight and you want a good performance-to-price ratio, the DBJ-1 (Dual Band J-pole-1) is an excellent choice.

In quantity, the materials cost about \$5 per antenna and what you get is a VHF/UHF base station antenna with $\lambda/2$ vertical performance on both VHF and UHF bands. If a small city builds a dozen of these antennas for schools, public buildings, etc it would cost about \$60. Not for one, but the entire dozen!

Since it is constructed using PVC pipe, it is UV protected and it is waterproof. To date I have personally constructed over 400 of these antennas for various groups and individuals and have had excellent results. One has withstood harsh winter conditions in the mountains of McCall, Idaho for four years.

The most common request from users is for a portable "roll-up" version of this antenna for backpacking or emergency use. To address this request, I will describe how the principles of the DBJ-1 can be extended to a portable roll-up antenna. Since it is the second version of this antenna, I call it the DBJ-2.

Principles of the DBJ-1

The earlier DBJ-1 is based on the J-pole,² shown in Figure 1. Unlike the popular ground plane antenna, it doesn't need ground

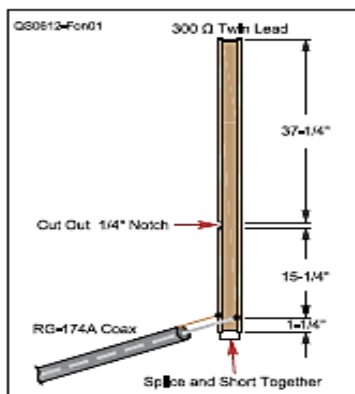

Figure 1 — The original 2 meter ribbon J-pole antenna.

radials. The DBJ-1 is easy to construct using inexpensive materials from your local hardware store. For its simplicity and small size, the DBJ-1 offers excellent performance and consistently outperforms a ground plane antenna.

Its radiation pattern is close to that of an ideal vertical dipole because it is end-fed, with virtually no distortion of the radiation pattern due to the feed line. A vertically polarized, center-fed dipole will always have some distortion of its pattern because the feed line comes out at its center, even when a balun is used. A vertically polarized, center-fed antenna is also physically more difficult to construct because of that feed line coming out horizontally from the center.

The basic J-pole antenna is a half-wave vertical configuration. Unlike a vertical dipole, which because of its center feed is usually mounted alongside a tower or some kind of metal supporting structure, the radia-

tion pattern of an end-fed J-pole mounted at the top of a tower is not distorted.

The J-pole works by matching a low impedance (50Ω) feed line to the high impedance at the end of a $\lambda/2$ vertical dipole. This is accomplished with a $\lambda/4$ matching stub shorted at one end and open at the other. The impedance repeats every $\lambda/2$, or every 360° around the Smith Chart. Between the shorted end and the high impedance end of the $\lambda/4$ shorted stub, there is a point that is close to 50Ω and this is where the 50Ω coax is connected.

By experimenting, this point is found to be about $1\frac{1}{4}$ inches from the shorted end on 2 meters. This makes intuitive sense since 50Ω is closer to a short than to an open circuit. Although the Smith Chart shows that this point is slightly inductive, it is still an excellent match to 50Ω coax. At resonance the SWR is below 1.2:1. Figure 1 shows the dimensions for a 2-meter J-pole. The $15\frac{1}{4}$ inch $\lambda/4$ section serves as the quarter wave matching transformer.

A commonly asked question is, "Why $15\frac{1}{4}$ inches?" Isn't a $\lambda/4$ at 2 meters about $18\frac{1}{2}$ inches? Yes, but twinlead has a reduced velocity factor (about 0.8) compared to air and must thus be shortened by about 20%.

A conventional J-pole configuration works well because there is decoupling of the feed line from the $\lambda/2$ radiator element since the feed line is in line with the radiating $\lambda/2$ element. Thus, pattern distortion is minimized. But this only describes a single band VHF J-pole. How do we make this into a dual band J-pole?

Adding a Second Band to the J-pole

To incorporate UHF coverage into a VHF J-pole requires some explanation. (A more detailed explanation is given in my February 2003 *QST* article.) First, a 2 meter antenna does resonate at UHF. The key word here is

¹Notes appear on page 40.

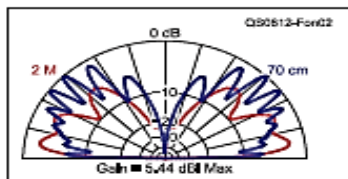

Figure 2 — Elevation plane pattern comparing 2 meter J-pole on fundamental and on third harmonic frequency (70 cm), with the antenna mounted 8 feet above ground. Most of the energy at the third harmonic is launched at 44°.

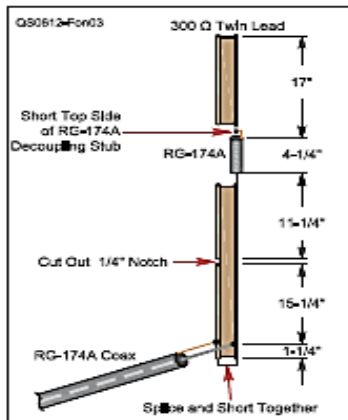

Figure 3 — The original DBJ-1 dual-band J-pole. The dimensions given assume that the antenna is inserted into a 3/4 inch Class 200 PVC pipe.

resonate. For example, any LC circuit can be resonant, but that does not imply that it works well as an antenna. Resonating is one thing; working well as an antenna is another. You should understand that a $\lambda/4$ 146 MHz matching stub works as a $3\lambda/4$ matching stub at 450 MHz, except for the small amount of extra transmission line losses of the extra $\lambda/2$ at UHF. The UHF signal is simply taking one more revolution around the Smith Chart.

The uniqueness of the DBJ-1 concept is that it not only resonates on both bands but also actually performs as a $\lambda/2$ radiator on both bands. An interesting fact to note is that almost all antennas will resonate at their third harmonic (it will resonate on any odd harmonic 3, 5, 7, etc.). This is why a 40 meter dipole can be used on 15 meters. The difference is that the performance at the third harmonic is poor when the antenna is

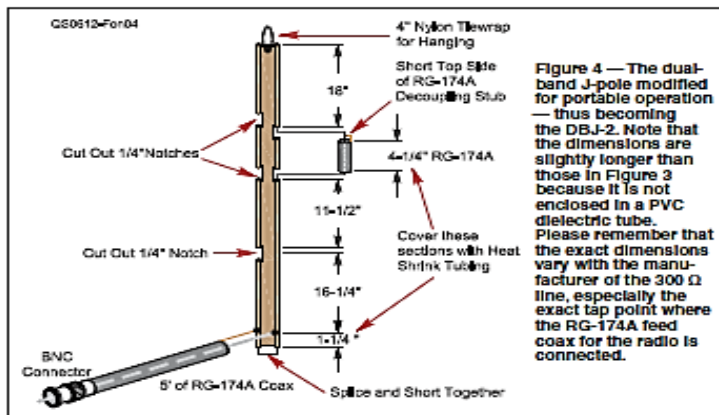

Figure 4 — The dual-band J-pole modified for portable operation — thus becoming the DBJ-2. Note that the dimensions are slightly longer than those in Figure 3 because it is not enclosed in a PVC dielectric tube. Please remember that the exact dimensions vary with the manufacturer of the 300 Ohm line, especially the exact tap point where the RG-174A feed coax for the radio is connected.



Figure 5 — The $\lambda/4$ UHF decoupling stub made of RG-174A, covered with heat shrink tubing. This is shown next to the BNC connector that goes to the transceiver.

used in a vertical configuration, as in the J pole shown in Figure 1. This can be best explained by a 19 inch 2 meter vertical over an ideal ground plane. At 2 meters, it is a $\lambda/4$ length vertical (approximately 18 inches). At UHF (450 MHz) it is a $3\lambda/4$ vertical. Unfortunately, the additional $\lambda/2$ at UHF is out of phase with the bottom $\lambda/4$. This means cancellation occurs in the radiation pattern and the majority of the energy is launched at a takeoff angle of 45°. This results in about a 4 to 6 dB loss in the horizontal plane compared to a conventional $\lambda/4$ vertical placed over a ground plane. A horizontal radiation pattern obtained from EZNEC is shown in Figure 2. Notice that the $3\lambda/4$ radiator has most of its energy at 45°.

Thus, although an antenna can be made to work at its third harmonic, its performance is poor. What we need is a simple, reliable method to decouple the remaining $\lambda/2$ at UHF of a 2 meter radiator, but have it remain electrically unaffected at VHF. We want independent $\lambda/2$ radiators at both VHF and UHF frequencies. The original DBJ-1 used a combination of coaxial stubs and 300 Ohm twinlead cable, as shown in Figure 3.

Refer to Figure 3, and start from the left hand bottom. Proceed vertically to the RG-174A lead in cable. To connect to the antenna, about 5 feet of RG-174A was used with a BNC connector on the other end. The $\lambda/4$ VHF impedance transformer is made from 300 Ohm twin lead. Its approximate length is 15 inches due to the velocity factor of the 300 Ohm material. The $\lambda/4$ piece is shorted at the bottom and thus is an open circuit (high impedance) at the end of the $\lambda/4$ section. This matches well to the $\lambda/2$ radiator for VHF. The 50 Ohm tap is about 1 1/4 inches from the short, as mentioned before.

For UHF operation, the $\lambda/4$ matching stub at VHF is now a $3\lambda/4$ matching stub. This is electrically a $\lambda/4$ stub with an additional $\lambda/2$ in series. Since the purpose of the matching stub is for impedance matching and not for radiation, it does not directly affect the radiation efficiency of the antenna. It does, however, suffer some transmission loss from the additional $\lambda/2$, which would not be needed if it were not for the dual band operation. I estimate this loss at about 0.1 dB. Next comes the $\lambda/2$ radiating element for UHF, which is about 12 inches. To

Table 1
Measured Relative Performance of the Dual-band Antenna at 146 MHz

VHF $\lambda/4$ GP 4 radials	VHF Flexible Antenna	Standard VHF J-Pole	Dual-Band J-Pole
0 dB reference	-5.9 dB	+1.2 dB	+1.2 dB

make it electrically terminate at 12 inches, a $\lambda/4$ shorted stub at UHF is constructed using RG-174A. The open end is then connected to the end of the 12 inches of 300 Ω twinlead. The open circuit of this $\lambda/4$ coax is only valid at UHF. Also, notice that it is 4 1/2 inches and not 6 inches due to the velocity factor of RG-174A, which is about 0.6.

At the shorted end of the 4 1/2 inch RG-174A is the final 18 inches of 300 Ω twinlead. Thus the 12 inches for the UHF $\lambda/2$, the 4 1/2 inches of RG-174A for the decoupling stub at UHF, and the 18 inches of twinlead provide for the $\lambda/2$ at 2 meters. The total does not add up to a full 36 inches that you might think. This is because the $\lambda/4$ UHF RG-174A shorted stub is inductive at 2 meters, thus slightly shortening the antenna.

Making it Portable

The single most common question that people asked regarding the DBJ-1 is how it could be made portable. The original DBJ-1 had the antenna inserted into Class 200 PVC pipe that was 6 feet long. This was fine for fixed operation but would hardly be suitable for portable use. Basically the new antenna had to have the ability to be rolled up when not in use and had to be durable enough for use in emergency communications.

The challenge was to transfer the concepts developed for the DBJ-1 and apply them to a durable roll-up portable antenna. After much thought and experimenting, I adopted the configuration shown in Figure 4.

The major challenge was keeping the electrical characteristics the same as the original DBJ-1 but physically constructing it from a continuous piece of 300 Ω twinlead. Any full splices on the twinlead would compromise the durability, so to electrically disconnect sections of the twinlead, I cut small 1/4 inch notches to achieve the proper resonances. I left the insulating backbone of the 300 Ω twinlead fully intact. I determined the two notches close to the $\lambda/4$ UHF decoupling stub by experiment to give the best SWR and bandwidth.

Because this antenna does not sit inside a dielectric PVC tube, the dimensions are about 5% longer than the original DBJ-1.

From March 2007 QST © ARRL

Table 2
Measured Relative Performance of the Dual-band Antenna at 445 MHz

UHF $\lambda/4$ GP 4 radials	UHF Flexible Antenna	Standard VHF J-Pole	Dual-Band J-Pole
0 dB reference	-2.0 dB	-5.5 dB	0.5 dB

is significant. I have confidence in these measurements since the flexible antenna is about -6 dB from that of the $\lambda/4$ ground plane antenna, which agrees well with the literature.

Also notice that at UHF, the loss for the flex antenna is only 2.0 dB, compared to the ground plane. This is because the flexible antenna at UHF is already 6 inches long, which is a quarter wave. So the major difference for the flexible antenna at UHF is the lack of ground radials.

Summary

I presented how to construct a portable, roll-up dual-band J-pole. I've discussed its basic theory of operation, and have presented experimental results comparing the DBJ-2 to a standard ground plane, a traditional 2 meter J-pole and a flexible antenna. The DBJ-2 antenna is easy to construct, is low cost and is very compact. It should be an asset for ARES applications. It offers significant improvement in both the VHF and UHF bands compared to the stock flexible antenna antenna included with a handheld transceiver.

If you do not have the equipment to construct or tune this antenna at both VHF and UHF, the antenna is available from the author tuned to your desired frequency. Cost is \$20. E-mail him for details.

Notes

¹E. Fong, "The DBJ-1: A VHF-UHF Dual-Band J-Pole," *QST*, Feb 2003, pp 28-40.

²J. Reynante, "An Easy Dual-Band VHF/UHF Antenna," *QST*, Sep 1994, pp 61-62.

Ed Fong was first licensed in 1968 as WN6IQN. He later upgraded to Amateur Extra class with his present call of WB6IQN. He obtained BSEE and MSEE degrees from the University of California at Berkeley and his PhD from the University of San Francisco. A Senior Member of the IEEE, he has 8 patents, 24 published papers and a book in the area of communications and integrated circuit design. Presently, he is employed by the University of California at Berkeley teaching graduate classes in RF design and is a Principal Engineer at National Semiconductor, Santa Clara, California working with CMOS analog circuits. You can reach the author at edison_fong@hotmail.com. 

KC9YIM's J-Pole

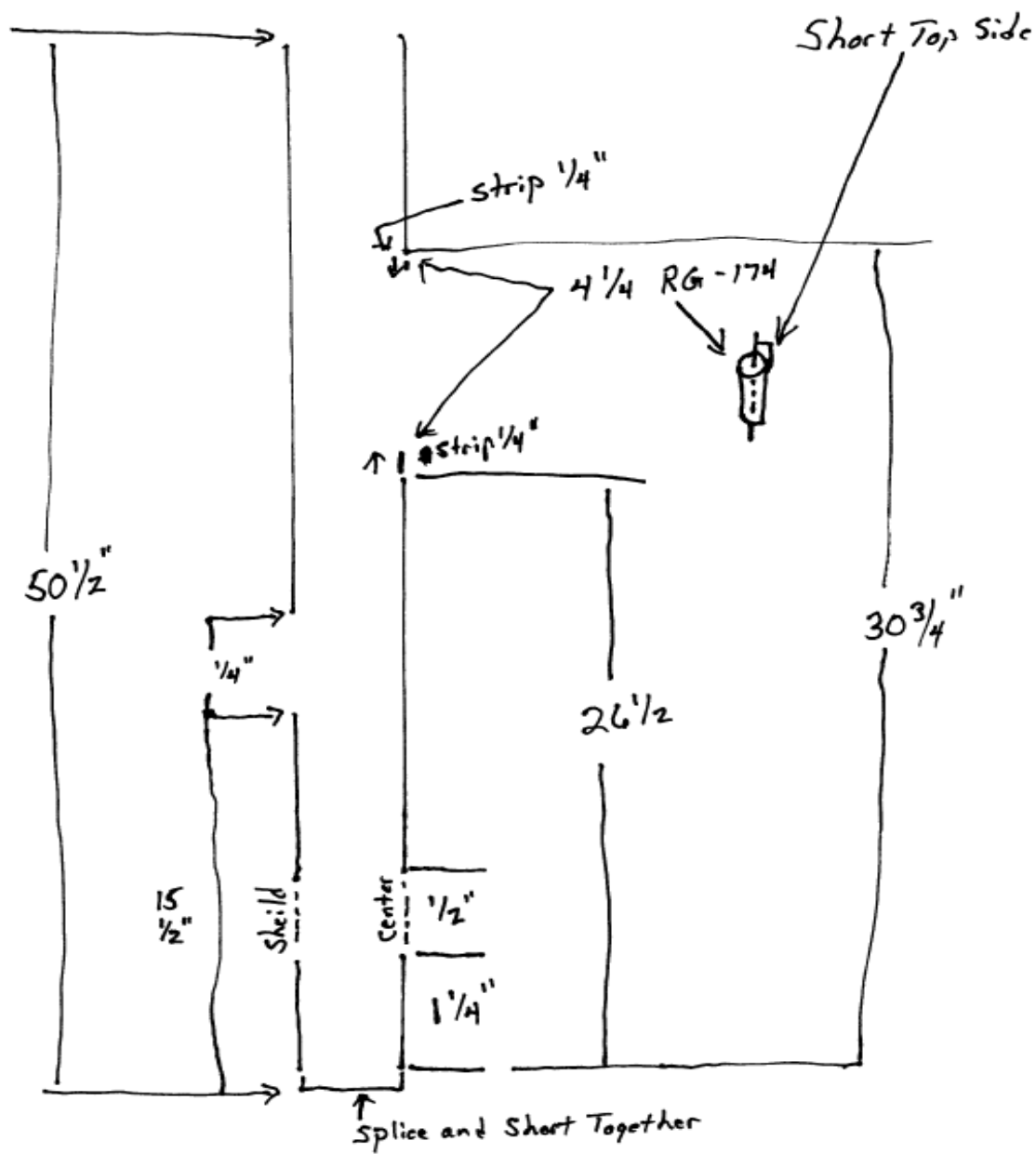



**KC9YIM's J-Pole
Performance**

Thank You